

Inboard Machine

Exclusive machine provided with measures to counter dust and fire

- Superior combined operation of front attachment and swing conduce to higher productivity than that of trimming dozers.
- Various measures are provided to counter dust and fire.
- Strong bucket made of Swedish steel for higher durability.
- Air jet device (option) fitted at the arm end for easy, safe wall cleaning.

● Example of Equipment ●

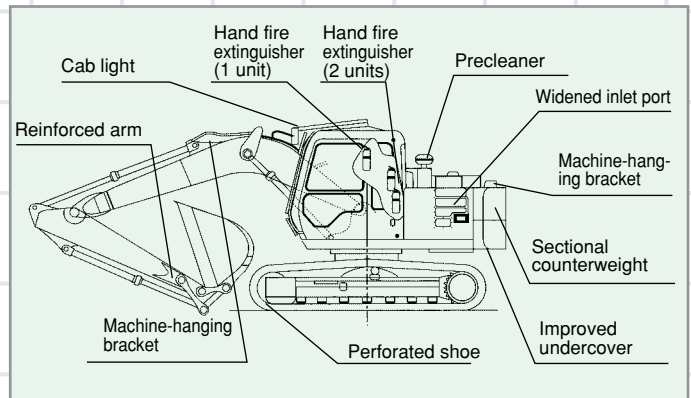
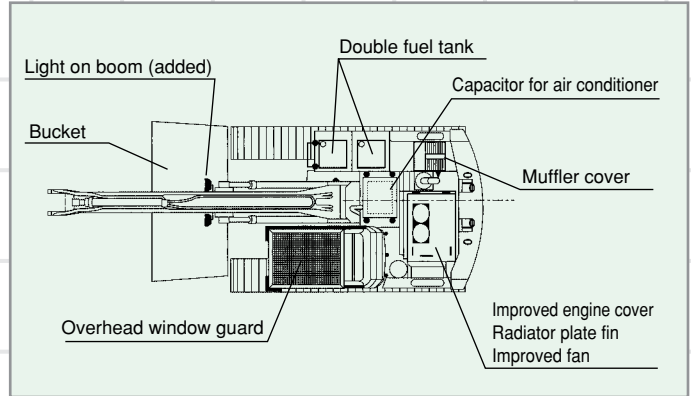

● Options ●



Items	Point	Remarks
Glass for overhead window	Visibility up	
Guards for front and overhead glass	Safety up	
Bucket	Productivity up	1.8m ³ , light type, Sweden steel
Reinforced arm (4 plates)	Durability up	1.8m ³ , light type, Sweden steel
Machine-hanging bracket	Increased hanging capacity	Boom × 2, Counterweight × 2
Boom step for reeving		Machine total weight: 12 400kg (11 200kg+1 200kg)
Sectional counterweight	Safety up	Boom (right) × 1, Cab roof × 2
Increased number of lights		(Conventional)80D (New) 95D
Increased battery capacity	Productivity up	Total: 500L
Fuel tank double filter		Prevention of fuel contamination
Precleaner		Prevention of dust suction
Perforated shoe	Heat balance up	Prevention of shoe link clogging
Enlarged radiator inlet port		Increase of engine cooling airflow
Enlarged radiator outlet port		
Large-size engine fan		
Improved undercover		
Plate-fin radiator	Maintainability up	Superior performance to wavy fin
Separated air conditioner capacitor		Easier radiator cleaning
Ceramic-clothed muffler	Fire prevention	
Covered muffler		Prevention of dust entrance
Sealed engine cover		
Hand fire extinguisher		Cab × 1, Engine room × 2