

LX230

HITACHI

LX230

W H E E L L O A D E R

- Engine Rated Power : 198 kW (270 PS)
- Operating Weight : 21 770 kg / 21 310 kg
- Bucket Capacity : ISO Heaped
3.1 m³ – 4.0 m³

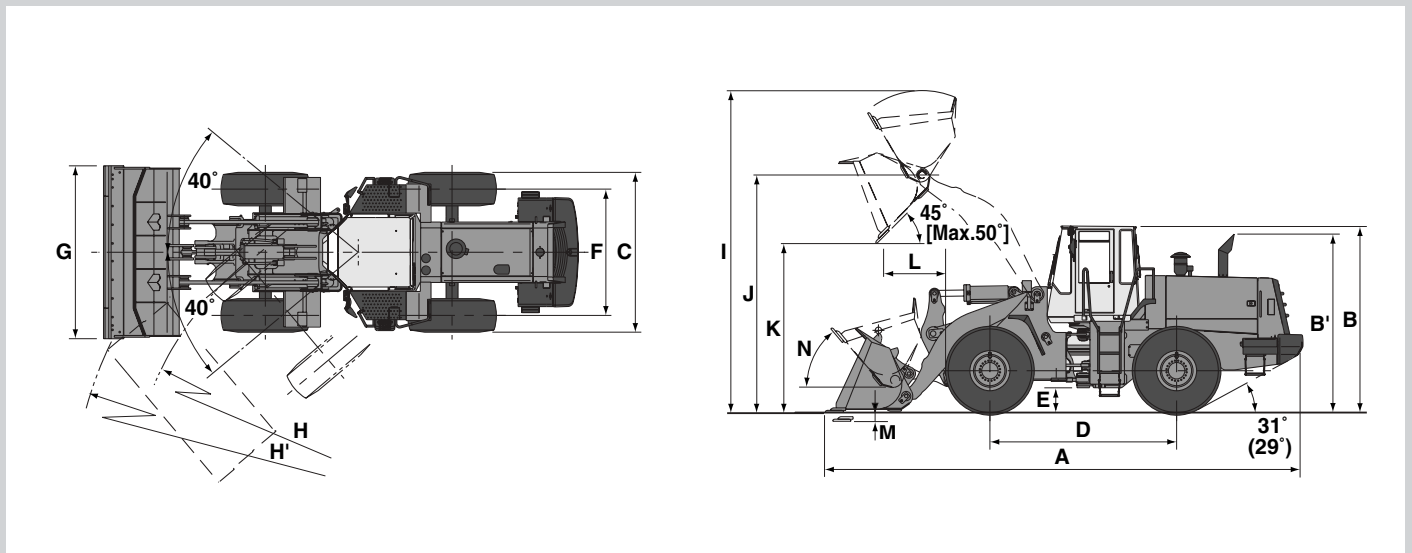

Note: Values shown in () are for optional 23.5 - 25 - 20PR tires.

Unit : mm

	LX230-7
A Overall length	8 700 / 8 650
B Height to top of cab	3 410 / 3 470
B' Height to top of exhaust	3 250 / 3 310
C Width over tires	2 930 / 2 980
D Wheel base	3 400
E Ground clearance	460 / 520
F Tread	2 300
G Bucket width	3 150
H Turning radius (Centerline of outside tire)	5 820
H' Loader clearance circle, bucket in carry position	6 890
I Overall operating height	5 865 / 5 925
J Height to bucket hinge pin, fully raised	4 325 / 4 385
K Dumping clearance 45 degree, full height	3 075 / 3 135
L Reach, 45 degree dump, full height	1 275 / 1 210
Reach, 45 degree dump, 7 ft (2.13 m) clearance	1 935 / 1 900
M Digging depth (Horizontal digging angle)	160 / 100
N Max. roll back at carry position	50 deg.
Tire size	26.5 - 25 - 20PR (L3) / 23.5 - 25 - 20PR (L3)

Note: General purpose bucket with bolt on cutting edges.



ENGINE

Model Mitsubishi 6D24TL
 Type 4-cycle water cooled, direct injection
 Aspiration Turbocharger and intercooler
 No. of cylinders 6
 Rated power
 DIN 6 272,net 198 kW (270 PS) at 2 100min⁻¹ (2 100 rpm)
 SAE J1349,net 198 kW (266 HP) at 2 100min⁻¹ (2 100 rpm)
 Bore and stroke 130 mm x 150 mm
 Piston displacement 11.945 L
 Electrical system 24 V with 0.96 kW, 50 A alternator
 Starting system 24 V x 7.0 kW electric motor
 Batteries 2 x 12 V / 916 CCA, 270-min. rated reserve
 Air cleaner Two element dry type with restriction indicator



POWER TRAIN

Transmission Torque converter, countershaft type powershift with computer-controlled automatic shift and manual shift features included.
 Torque converter Three element, single stage, single phase
 Main clutch Wet hydraulic, multi-disc type
 Cooling method Forced circulation type
 Travel speed* : km/h

	Forward / Reverse
1st	7.0 / 7.5
2nd	12.5 / 13.5
3rd	20.0 / 21.5
4th	32.5 / 35.0
	<i>*With 23.5-25-20PR (L3) tires</i>
	Forward / Reverse
1st	7.5 / 8.5
2nd	13.0 / 14.5
3rd	21.0 / 23.0
4th	34.5 / 36.5
	<i>*With 26.5-25-20PR (L3) tires</i>



AXLE AND FINAL DRIVE

Drive system Four-wheel drive system
 Front & rear axle Semi-floating
 Front : Fixed to the front frame
 Rear : Trunnion support
 Reduction and differential gear Two stage reduction with torque proportional differential
 Oscillation angle ± 12° ; total 24°
 Final drives Heavy-duty planetary, mounted inboard



TIRES (tubeless, nylon body)

Standard 23.5-25-20PR (L3)
 Optional Refer to standard & optional equipment list



BRAKES

Service brakes Inboard mounted fully hydraulic 4 wheel wet disc brake.
 Front & rear independent brake circuit
 Parking brake Wet multiple disc mechanical type built in transmission



STEERING SYSTEM

Type Articulated frame steering
 Steering mechanism Full hydraulic power steering
 Steering angle Each direction 40°; total 80°
 Relief pressure 18.6 MPa (190 kgf/cm²)
 Cylinders Two double-acting piston type
 No. x Bore x Stroke 2 x 80 mm x 542 mm
 Minimum turning radius at the centerline of outside tire 5.82 m



HYDRAULIC SYSTEM

Arm and bucket are controlled by independent control lever
 Arm controls Four position valve ; Raise, hold, lower, float
 Bucket controls with automatic bucket return-to-dig control Three position valve ; Roll back, hold, dump
 Main pump Gear type 185 L/min @2 100 min⁻¹ (rpm) at 17 160 KPa (175 kgf/cm²)
 Steering pump Gear type 205 L/min @2 100 min⁻¹ (rpm) at 20 590 KPa (210 kgf/cm²)
 Brake and assist pump Gear type 27 L/min @2 100 min⁻¹ (rpm) at 6 370 KPa (65 kgf/cm²)
 Charging pump Double gear type with two discharge ports
 Front pump Front 81 L/min @2 100 min⁻¹ (rpm) at 2 450 KPa (25 kgf/cm²)
 Rear pump Rear 91 L/min @2 100 min⁻¹ (rpm) at 490 KPa (5 kgf/cm²)
 Relief pressure setting 20 590 KPa (210 kgf/cm²)
 Hydraulic cylinders
 Type Two arm and one bucket, double acting type
 No. x Bore x Stroke Arm : 2 x 170 mm x 920 mm
 Bucket : 1 x 210 mm x 570 mm
 Filters Full-flow 15 micron return filter in reservoir
 Hydraulic cycle times
 Lift arm raise 6.4 s
 lower 3.6 s
 Bucket dump 1.5 s
 Total 11.5 s



SERVICE REFILL CAPACITIES

Fuel tank 345 L
 Engine coolant 80 L
 Engine oil 38 L
 Torque convertor & transmission 40 L
 Front axle differential & wheel hubs 48 L
 Rear axle differential & wheel hubs 48 L
 Hydraulic reservoir 124 L



DIMENSIONS & SPECIFICATIONS

Arm type			Standard arm				
			General purpose			Rock bucket	
			With bolt-on cutting edges	With bolt-on teeth	With bolt-on teeth & segments	With bolt-on teeth	With bolt-on teeth & segments
Bucket type	ISO heaped	m ³	4.0	3.8	4.0	3.3	3.4
	ISO struck	m ³	3.5	3.2	3.4	2.8	2.9
Bucket width		mm	3 150	3 150	3 150	3 150	3 150
Working range							
	Dumping clearance 45 degree, full height	mm	3 135	3 000	3 000	3 055	3 055
	Reach, 45 degree dump, full height	mm	1 210	1 310	1 310	1 255	1 255
	Reach, 45 degree dump, 7 ft (2.13 m) clearance	mm	1 900	1 940	1 940	1 910	1 910
	Reach with arm horizontal and bucket level	mm	2 760	2 935	2 935	2 860	2 860
	Digging depth (Horizontal digging angle)	mm	100	110	110	110	110
	Overall operating height	mm	5 925	5 925	5 925	5 900	5 900
	Overall length (Bucket on ground)	mm	8 650	3 705	3 705	8 760	8 760
	Loader clearance circle, bucket in carry position	mm	6 890	6 940	6 940	6 920	6 920
Static tipping load *	Straight	kgf	16 850	17 100	16 900	16 650	16 450
	Full 40 degree turn	kgf	14 880	14 750	14 550	14 300	14 100
Breakout force		kN	198	213	202	225	214
		(kgf)	(20 200)	(21 700)	(20 600)	(23 000)	(21 800)
Operating weight *		kgf	21 700	21 610	21 790	22 110	22 290

Arm type			High-lift arm	
			General purpose	
			With bolt-on cutting edges	With bolt-on teeth
Bucket type	ISO heaped	m ³	3.3	3.1
	ISO struck	m ³	2.8	2.7
Bucket width		mm	3 150	3 150
Working range				
	Dumping clearance 45 degree, full height	mm	3 690	3 555
	Reach, 45 degree dump, full height	mm	1 090	1 190
	Reach, 45 degree dump, 7 ft (2.13 m) clearance	mm	2 160	2 215
	Reach with arm horizontal and bucket level	mm	2 895	3 070
	Digging depth (Horizontal digging angle)	mm	100	110
	Overall operating height	mm	6 220	6 220
	Overall length (Bucket on ground)	mm	8 865	9 050
	Loader clearance circle, bucket in carry position	mm	7 000	7 060
Static tipping load *	Straight	kgf	14 600	14 700
	Full 40 degree turn	kgf	12 600	12 700
Breakout force		kN	211	229
		(kgf)	(21 500)	(23 400)
Operating weight *		kgf	21 790	21 700

Notes: 1. All dimensions, weight and performance data based on ISO 6746-1:1987, ISO 7131:1997 and ISO 7546:1983

2. Static tipping load and operating weight marked with * include 26.5-25-20PR (L3) tires (No ballast) with lubricants, coolant, full fuel tank and operator. Machine stability and operating weight depend on counterweight, tire size and other attachments.

Tires and Options	Change in operating weight	Change in tipping load	
		Straight	Full turn
		kg	kg
23.5-25-20PR (L2) Bias ply	- 694	- 530	- 470
23.5-25-20PR (L3) Bias ply	- 590	- 440	- 390
23.5-25-20PR (L4) Bias ply	- 250	- 180	- 160
23.5-25-20PR (L5) Bias ply	66	50	40
26.5-25-20PR (L3) Bias ply	-8	0	0
26.5-25-20PR (L4) Bias ply	—	—	—
26.5-25-20PR (L5) Bias ply	—	—	—
23.5 R25 (L3 type) Radial ply	- 298	- 230	- 200
23.5 R25 (L5 type) Radial ply	—	—	—
26.5 R25 (L3 type) Radial ply	—	—	—
26.5 R25 (L5 type) Radial ply	—	—	—
FRP roof canopy (In lieu of ROPS/FOPS cab)	—	—	—
ROPS/FOPS canopy (In lieu of ROPS/FOPS cab)	—	—	—
Log grapple (Pin on type)*	1 290	1 020	900
Lumber grapple (Pin on type)	—	—	—
Counterweight, CW*A	320	800	710
Counterweight, CW*B	930	1 940	1 710

Note: * With counterweight CW*A, counterweight CW*B and 23.5-25-24PR (L3) tires



BUCKET SELECTION GUIDE

			Bucket Capacity	Material density kg/m ³							
				1 000	1 200	1 400	1 600	1 800	2 000	% Bucket Fill Factor	
										115%	100% 95%
Standard arm	General purpose	With bolt-on cutting edges	4.0 m ³								
		With bolt-on teeth	3.8 m ³								
		With bolt-on teeth & segments	4.0 m ³								
	Rock bucket	With bolt-on teeth	3.3 m ³								
		With bolt-on teeth & segments	3.4 m ³								
High-lift arm	General purpose	With bolt-on cutting edges	3.3 m ³								
		With bolt-on teeth	3.1 m ³								

 **Hitachi Construction Machinery Co., Ltd.**

Head Office: 5-1 Koraku 2-chome, Bunkyo-ku,
Tokyo 112-8563, Japan

Telephone: (03)3830-8050

Facsimile: (03)3830-8204

*These specifications are subject to change without notice.
Illustrations and photos show the standard models, and may or may not include optional
equipment, accessories, and all standard equipment with some differences in color and features.
Before use, go through Operators Manual for proper operation.*

KL-E124

03.09 (KA/KA, MT₃)

Printed in Japan