

ZAXIS75US SERIES  
Short-Tail-Swing Version

HITACHI

# ZAXIS 75 US

- Engine Rated Power : 40.5 kW (55 PS)
- Operating Weight : 7 100 kg
- Backhoe Bucket SAE, PCSA Heaped : 0.13 — 0.33 m<sup>3</sup>  
CECE Heaped : 0.12 — 0.29 m<sup>3</sup>



# TOUGH TIGHT SHORT-TAIL-SWING ZAXIS75US

## High Productivity

### A truly high-performance machine

- 11% more travel power (compared to former model): 5.0 km travel speed.
- 10% more swing power (compared to former model).
- Rear-end swing radius 1.21 m (540 mm less than ZAXIS70).
- Faster front operations.
- Superior stability.
- Wide range of applications.
- 3 service ports (valves) as standard equipment.

## Lower Running Costs

### Stronger structural component design

- Increased wear resistance of bucket joint: WC thermal spraying.

## Lower Maintenance Costs

### Reduced maintenance time and expense

- Extended time between bucket joint section lubrications
- Easy maintenance.
- Extended replacement interval for hydraulic oil filter (Every 1000 hours).

## US-exclusive CRES Cab

### (Corner Reinforced Structure)

### Provides excellent operator comfort

\* The CRES cab meets OPG top guard level I (ISO).

- Low noise and low vibration in cab.

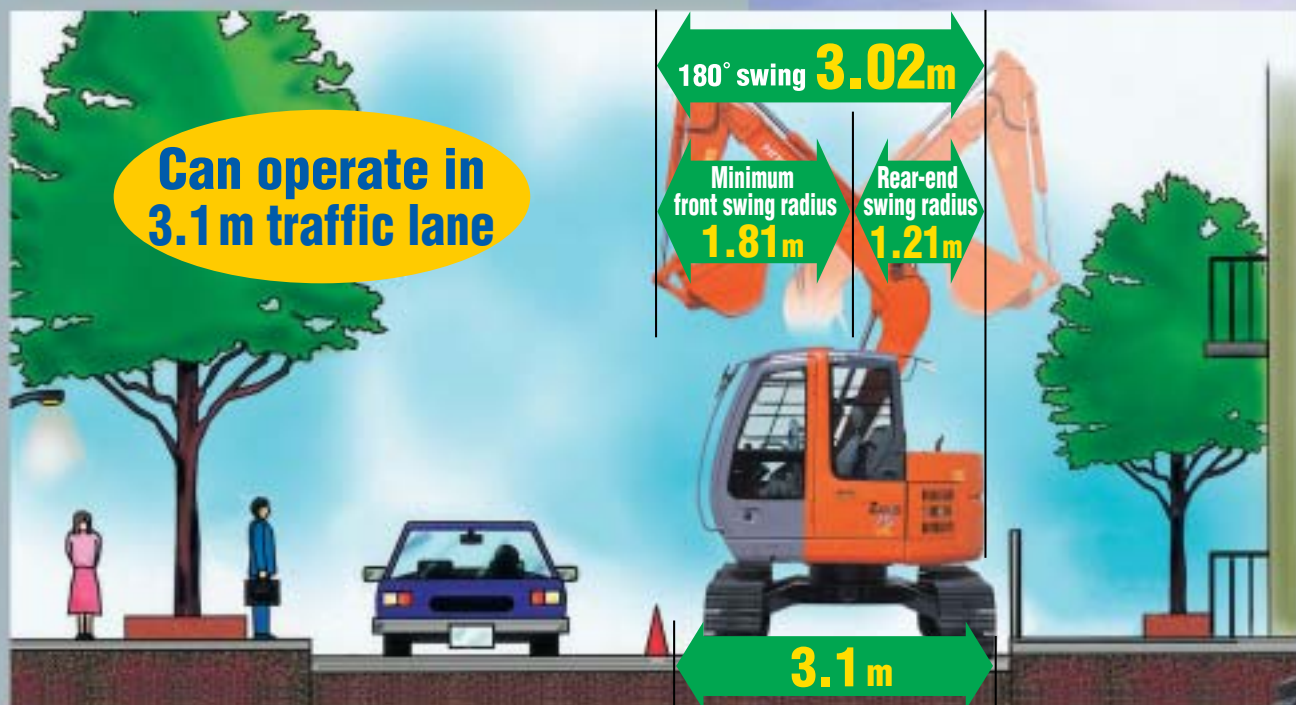

**Notes :** 1. Never leave the front attachment in a raised position. Make sure the front attachment is lowered to the ground before leaving the equipment unattended. (Some of the pictures in this catalog show an unmanned machine with attachments in an operating position. These were taken for demonstration purposes only and the actions shown are not recommended under normal operating conditions.)  
2. Caution plates on the machine will vary according to country.  
3. Photos include optional equipment.

Improved productivity / Shorter work time

# FUTURISTIC POWER



-540 mm Compared to ZAXIS70

## Wide Range of Job Applications

### Operates in Tight Job Sites

The rear-end swing radius ZAXIS75US is 540 mm smaller than the ZAXIS70, the ZAXIS75US can operate efficiently in tight job sites.

### Swing Power You Can Depend On (compared to former model)

Utilizes an independent swing circuit and new shock-resistant mechanism.

This enhances the multiple function operability and applicability to allow for rhythmical slope tamping and compacting operations.



### Faster Front Operations (compared to former model)

The arm circuit uses a new combination of 3 pumps to provide not only independent speed but also increased speed during leveling operations as well.



### Increased Stability (compared to ZAXIS70)

The large undercarriage and solid cast counterweight help boost stability.

8% increased to the front  
12% increased to the sides

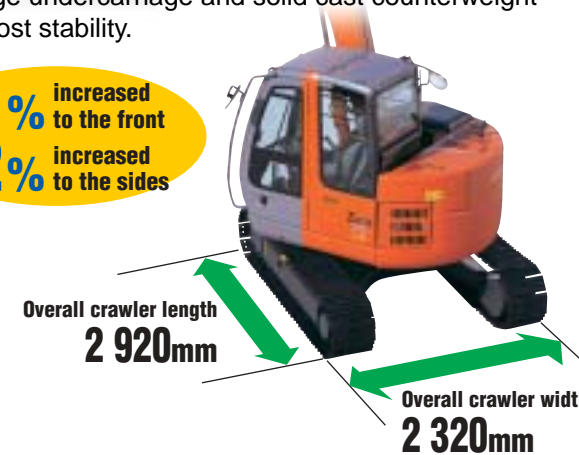

Comfort

# FUTURISTIC SPACE CREATES COMFORT



## Comfort Increased to Reduce Operator Fatigue

A reinforced track X-frame, D-type frame and rigid cab bed work together with the silicone-filled rubber cushions to reduce noise and vibration. Lower noise and vibration contribute to less operator fatigue.

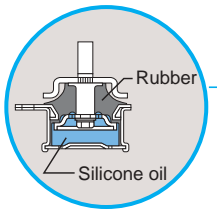
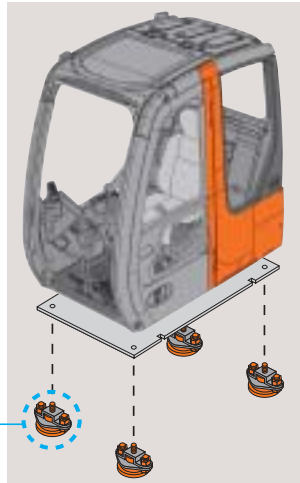

**One-glance Monitor Panel**



**Well-positioned Switches**

## Auto Control Air Conditioner (Option)

Simply set the temperature and forget about it. Ducts are positioned to promote even air flow throughout the cab.



\* Illustration shows a sample of the air flow during bi-level control.



Easy lock front window latch



Slide window



Storage box



Drink holder

## SAFETY

### Corner Reinforced Structure (CRES) Cab

\* The CRES cab meets OPG top guard level 1 (ISO).

This cab structure is formed from strong steel pipes to help it withstand external forces.

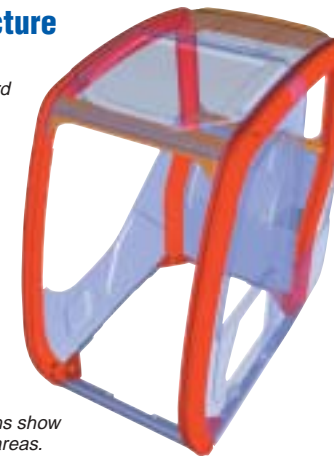

Red sections show reinforced areas.

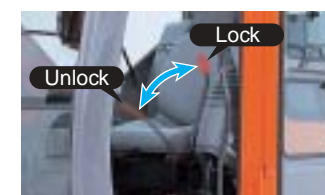

Pilot-control shut-off lever



Left side rearview mirror



Seat belt



Right side rearview mirror

Easy maintenance and high durability

# FUTURISTIC FUNCTIONS KEEP COSTS DOWN



## Equipment Operation Status Report

Onboard ICX  
(Information  
Controller)

PC

Z A X I S

# INFORMATION TECHNOLOGY SUPPORT

Providing the data  
for making  
the right decisions.

### Information Services for Equipment

- Operation record
- Error record
- Alarm record
- Frequency distribution  
Radiator coolant etc.  
and others.

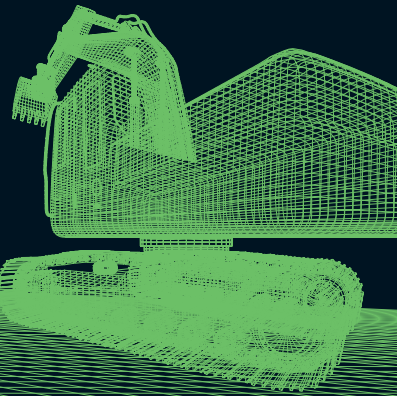
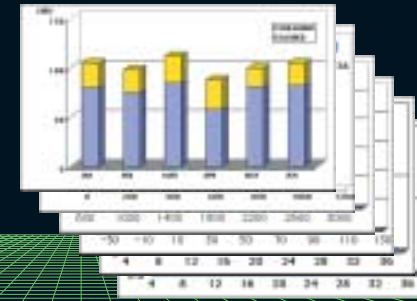

## Lower running costs

## Smart Saving

Advanced technology helps reduce maintenance costs

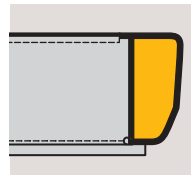

### Strong Upper Structure Supports Tough Operations

Reinforced main frame (D-Type) is used.

Increased strength

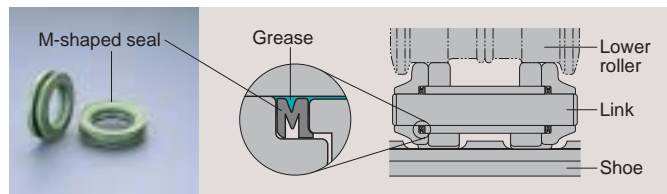

### Longer Track Link Service Life

The M-shaped track link seal is used to enhance grease retention.



### WC (Tungsten Carbide) Thermal Spraying

Used at arm end and bucket connection to increase wear resistance and reduce jerking.

### 500 Hours Between Lubrication for Bucket Joint Section and Front Sections (Compared to former model)

The use of the WC thermal spraying process has helped dramatically increase the time between lubrication. (See the Operator's Manual)

Bucket component lubrication 100 → 500 hours

\* Estimated values. The actual time between lubrication will vary according to actual work conditions.

### Hydraulic Oil Filter Only Needs Replacement Every 1000 Hours

The hydraulic oil filter can be used nearly twice as long as the previous model, dramatically reducing maintenance time and expense.

1000 hours between hydraulic oil filter replacement

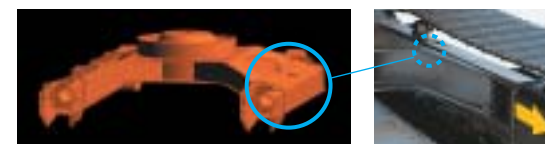

### Undercarriage Designed for Easy Mud Removal

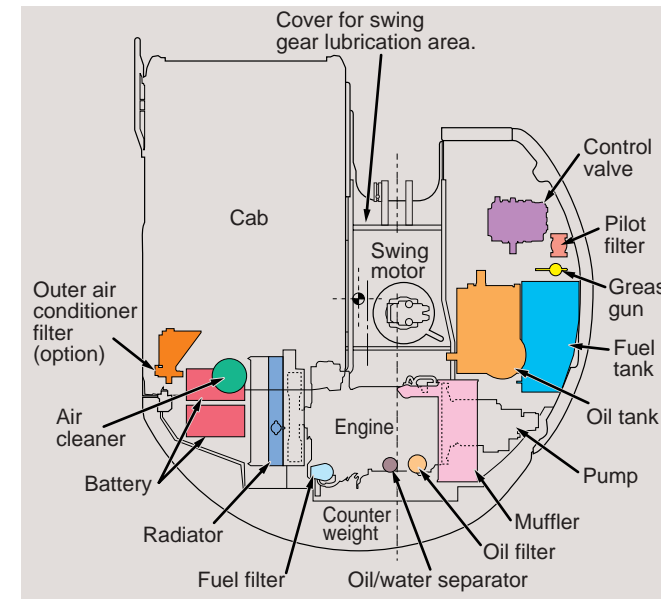

### Servicing Access is at Ground Level to Speed Inspection and Maintenance

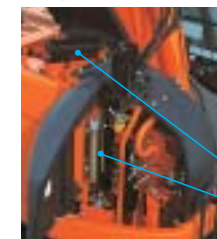

Convenient space for storing tool box and grease gun.

A wide maintenance area helps speed crucial inspection and repair operations.

Tool box  
Grease gun

### Environmentally Friendly

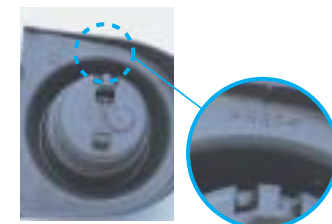

#### ● Labeled Plastic Parts

The plastic parts indicate the type of plastic used to help speed recycling.

#### ● Lead-free Wiring

#### ● Aluminium Radiator and Oil Cooler

Notes : The photo shows a cover opened at the time of the inspection. Be sure to close the cover at the time of the operation.

## ENGINE

Model .....Isuzu CC-4JG1  
 Type ..... 4-cycle water-cooled, direct injection  
 No. of cylinders ..... 4  
 Rated power  
 DIN 6271, net ..... 40.5 kW (55 PS) at 2 100 min<sup>-1</sup> (rpm)  
 SAE J1349, net ..... 40 kW (54 HP) at 2 100 min<sup>-1</sup> (rpm)  
 Maximum torque ..... 196 N·m (20 kgf·m, 145 lbf·ft)  
 at 1 800 min<sup>-1</sup> (rpm)  
 Piston Displacement ..... 3.059 L (187 in<sup>3</sup>)  
 Bore and stroke ..... 96 mm x 107 mm (3.8" x 4.2")  
 Batteries ..... 2 x 12 V / 52 AH  
 Governor ..... Mechanical speed control with stepping motor

## HYDRAULIC SYSTEM

- Swing-independent 3-pump hydraulic system
- OHS(Optimum Hydraulic System)assures fully independent and combined operations
- Auto-idling system
- New-type automatic 2-speed motor increases traction force and travel speed

Main pumps ..... 2 variable displacement axial piston pumps (Main)  
 Maximum oil flow ..... 2 x 69.3 L/min (18.3 US gpm, 15.2 Imp gpm)  
 Main pump ..... 1 gear pump (Swing)  
 Maximum oil flow ..... 52.5 L/min (13.9 US gpm, 11.6 Imp gpm)  
 Pilot pump ..... 1 gear pump  
 Max. oil flow ..... 22.5 L/min (5.9 US gpm, 5.0 Imp gpm)

### Hydraulic Motors

Travel ..... 2 variable displacement axial piston motors  
 Swing ..... 1 axial piston motor

### Relief Valve Settings

Implement circuit ..... 26.0 MPa (265 kgf/cm<sup>2</sup>, 3 770 psi)  
 Swing circuit ..... 26.0 MPa (265 kgf/cm<sup>2</sup>, 3 770 psi)  
 Travel circuit ..... 31.4 MPa (320 kgf/cm<sup>2</sup>, 4 550 psi)  
 Pilot circuit ..... 3.9 MPa (40 kgf/cm<sup>2</sup>, 570 psi)

### Hydraulic Cylinders

High-strength piston rods and tubes. Cylinder cushion mechanisms provided in boom and arm cylinders to absorb shock at stroke ends.

### Dimensions

	Qty.	Bore	Rod diameter
Boom	1	115 mm (4.53")	65 mm (2.56")
Arm	1	95 mm (3.74")	60 mm (2.36")
Bucket	1	85 mm (3.35")	55 mm (2.17")

### Hydraulic Filters

Hydraulic circuits use high-quality hydraulic filters. A suction filter is incorporated in the suction line, and full-flow filters in the return line and swing/travel motor drain lines.

## CONTROLS

Pilot controls. Hitachi's original shockless valve and quick warm-up system built in the pilot circuit.  
 Implement levers ..... 2  
 Travel levers with pedals ..... 2

## UPPERSTRUCTURE

### Revolving Frame

Welded sturdy box construction, using heavy-gauge steel plates for ruggedness. D-section frame for resistance to deformation.

### Swing Mechanism

Axial piston motor with planetary reduction gear is bathed in oil. Swing circle is single-row, shear-type ball bearing with induction-hardened internal gear. Internal gear and pinion gear are immersed in lubricant. Swing parking brake is spring-set/hydraulic-released disc type.  
 Swing speed ..... 11.0 min<sup>-1</sup> (rpm)

### Operator's Cab

US-exclusive cab, independent and roomy cab 1 005 mm (40") wide by 1 675 mm (66") high, conforming to ISO\* Standards. Reinforced glass windows on 4 sides for visibility. Openable front windows (upper and lower). Adjustable reclining seat.

\* International Standardization Organization

## UNDERCARRIAGE

### Tracks

Tractor-type undercarriage. Welded track frame using selected materials. Side frame welded to track frame. Lubricated track rollers, idlers, and sprockets with floating seals.

Track shoes with triple grousers made of induction-hardened rolled alloy. Flat and triangular shoes are also available. Heat-treated connecting pins with dirt seals. Hydraulic (grease) track adjusters with shock-absorbing recoil springs.

### Numbers of Rollers and Shoes on Each Side

Upper rollers ..... 1  
 Lower rollers ..... 5  
 Track shoes ..... 40

### Travel Device

Each track driven by 2-speed axial piston motor through planetary reduction gear for counterrotation of the tracks. Sprockets are replaceable.

Parking brake is spring-set/hydraulic-released disc type. Travel shockless relief valve built in travel motor absorbs shocks when stopping travel.

Travel speeds ..... High : 0 to 5.0 km/h (3.1 mph)  
 Low : 0 to 3.3 km/h (2.1 mph)

Maximum traction force ..... 60 kN (6 120 kgf, 13 500 lbf)  
 Gradeability ..... 35° (70%) continuous

## WEIGHTS AND GROUND PRESSURE

### ZAXIS75US-A

Equipped with 3.72 m (12'2") boom, 1.62 m (5'4") arm and 0.28 m<sup>3</sup> (0.37 yd<sup>3</sup>: SAE, PCSA heaped) bucket.

Shoe type	Shoe width	Standard undercarriage	
		Operating weight	Ground pressure
Triple grouser	450 mm (18")	7 100 kg (15 700 lb)	30 kPa (0.31 kgf/cm <sup>2</sup> , 4.40 psi)
	600 mm (24")	7 300 kg (16 100 lb)	24 kPa (0.24 kgf/cm <sup>2</sup> , 3.41 psi)
Pad	450 mm (18")	7 200 kg (15 900 lb)	31 kPa (0.32 kgf/cm <sup>2</sup> , 4.45 psi)
Rubber	450 mm (18")	7 100 kg (15 700 lb)	30 kPa (0.31 kgf/cm <sup>2</sup> , 4.40 psi)
Triangular	500 mm (20")	7 300 kg (16 100 lb)	28 kPa (0.29 kgf/cm <sup>2</sup> , 4.12 psi)
	700 mm (28")	7 400 kg (16 300 lb)	21 kPa (0.21 kgf/cm <sup>2</sup> , 3.00 psi)
Flat	450 mm (18")	7 300 kg (16 100 lb)	31 kPa (0.32 kgf/cm <sup>2</sup> , 4.45 psi)

Weights of the basic machines [including 1 380 kg (3 040 lb), counterweight and triple grouser shoes, excluding front-end attachment, fuel, hydraulic oil, engine oil and coolant etc.] are:

ZAXIS75US-A ..... 5 800 kg (12 800 lb) with 450 mm (18") shoes

### Buckets

Capacity		Width		No. of teeth	Weight	Recommendation	
						ZAXIS75US-A	
SAE, PCSA heaped	CECE heaped	Without side cutters	With side cutters			1.62 m (5'4") arm	2.12 m (6'11") arm
0.13 m <sup>3</sup> (0.17 yd <sup>3</sup> )	0.12 m <sup>3</sup>	360 mm (14")	450 mm (18")	3	140 kg (310 lb)	⊙	⊙
0.17 m <sup>3</sup> (0.22 yd <sup>3</sup> )	0.15 m <sup>3</sup>	450 mm (18")	550 mm (22")	3	170 kg (375 lb)	⊙	⊙
0.19 m <sup>3</sup> (0.25 yd <sup>3</sup> )	0.17 m <sup>3</sup>	490 mm (19")	590 mm (23")	3	175 kg (390 lb)	⊙	⊙
0.23 m <sup>3</sup> (0.30 yd <sup>3</sup> )	0.20 m <sup>3</sup>	560 mm (22")	650 mm (26")	3	185 kg (408 lb)	⊙	⊙
0.28 m <sup>3</sup> (0.37 yd <sup>3</sup> )	0.24 m <sup>3</sup>	660 mm (26")	750 mm (30")	4	210 kg (463 lb)	⊙	⊙
0.33 m <sup>3</sup> (0.43 yd <sup>3</sup> )	0.29 m <sup>3</sup>	770 mm (30")	860 mm (34")	5	230 kg (507 lb)	⊙	—
*1 0.23 m <sup>3</sup> (0.30 yd <sup>3</sup> )	0.20 m <sup>3</sup>	560 mm (22")	650 mm (26")	3	190 kg (419 lb)	⊙	⊙
*1 0.28 m <sup>3</sup> (0.37 yd <sup>3</sup> )	0.24 m <sup>3</sup>	660 mm (26")	750 mm (30")	4	215 kg (274 lb)	⊙	⊙
*1 0.33 m <sup>3</sup> (0.43 yd <sup>3</sup> )	0.29 m <sup>3</sup>	770 mm (30")	860 mm (34")	5	240 kg (529 lb)	⊙	—

\*1 Reinforced tooth bucket

⊙ Suitable for materials with density of 1 800 kg/m<sup>3</sup> (3 030 lb/yd<sup>3</sup>) or less  
 — Not applicable

## SERVICE REFILL CAPACITIES

	liters	US gal	Imp gal
Fuel tank	120.0	31.7	26.4
Engine coolant	9.2	2.4	2.0
Engine oil	12.0	3.2	2.7
Travel final device (each side)	2.5	0.66	0.55
Hydraulic system	90.0	23.8	19.8
Hydraulic oil tank	51.0	13.5	11.2

## BACKHOE ATTACHMENTS

Boom and arms are of welded, box-section design. 3.72 m (12'2") boom, 1.62 m (5'4") and 2.12 m (6'11") arms are available. Bucket is of welded steel structure. Side clearance adjust mechanism provided on the bucket joint bracket.

## DIMENSIONS

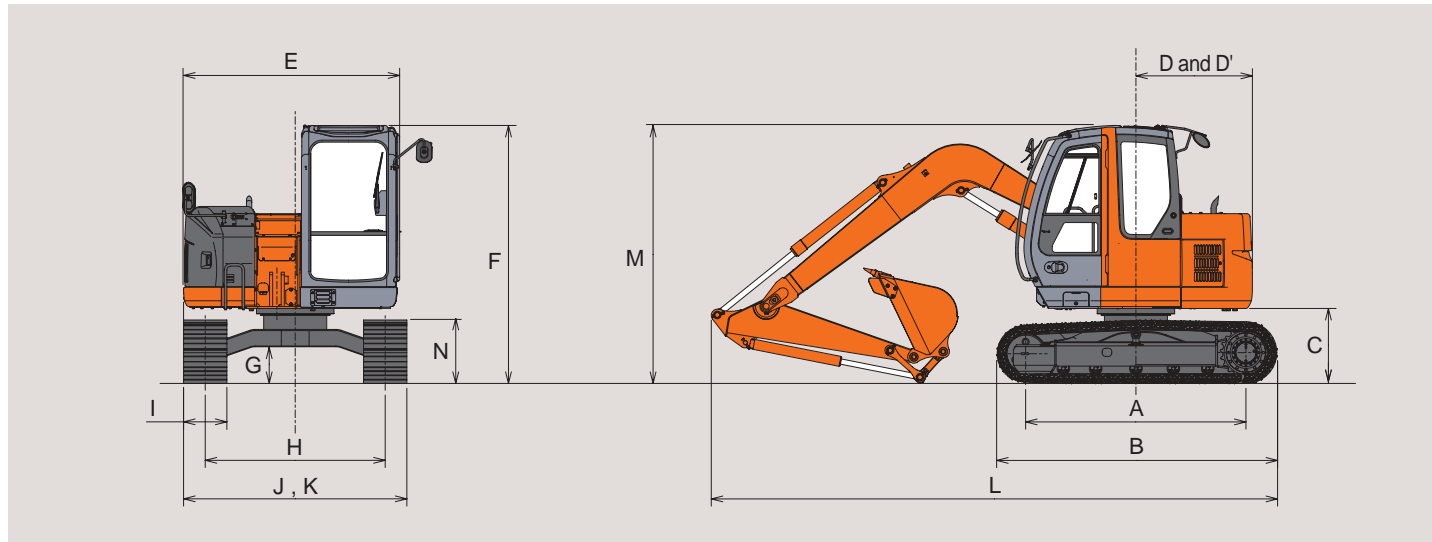

Unit: mm (ft in)

		ZAXIS75US-A	
A	Distance between tumbler	2 290 (7'6")	
B	Undercarriage length	2 920 (9'7")	
C	Counterweight clearance	*760 (2'6")	
D	Rear-end swing radius	1 210 (4'0")	
D'	Rear-end length	1 210 (4'0")	
E	Overall width of upperstructure	2 250 (7'5")	
F	Overall height of cab	2 690 (8'10")	
G	Min. ground clearance	*360 (1'2")	
H	Track gauge	1 870 (6'2")	
I	Track shoe width	G 450 (18")	G 600 (24")
J	Undercarriage width	2 320 (7'7")	
K	Overall width	2 320 (7'7")	
L	Overall length	With 1.62 m (5'4") arm	5 870 (19'3")
		With 2.12 m (6'11") arm	5 950 (19'6")
M	Overall height of boom	With 1.62 m (5'4") arm	2 690 (8'10")
		With 2.12 m (6'11") arm	2 830 (9'3")
N	Track height With triple grouser shoes	655 (2'2")	

\* Excluding track shoe lug. G: Triple grouser shoe P: Pad crawler

## ZAXIS75US-A with Dozer blade (Option)

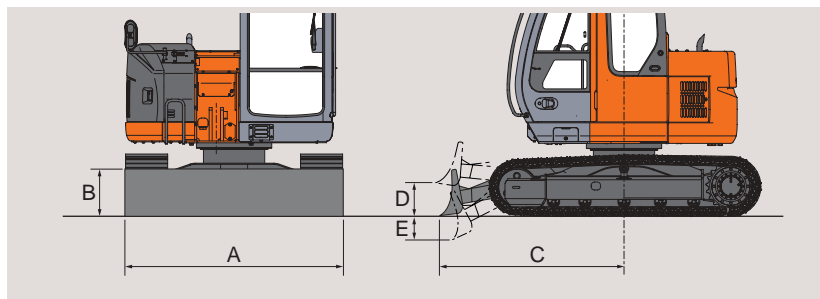

Equipped with 3.72 m (12'2") boom, 1.62 m (5'4") arm, 450mm (18") triple grouser shoe and 0.28 m<sup>3</sup> (0.37 yd<sup>3</sup>; SAE, PCSA heaped) for ZAXIS75US-A bucket.

Operating weight ..... 7 600 kg (16 800 lb)  
Ground pressure ..... 33 kPa (0.34 kgf/cm<sup>2</sup>, 4.83 psi)

A Overall width of blade ..... 2 320 mm (7'7")  
B Overall height of blade ..... 430 mm (1'5")  
C Blade distance ..... 1 920 mm (6'4")  
D Max. raising height above ground ..... 420 mm (1'5")  
E Max. lowering depth from ground ..... 260 mm (10")

## WORKING RANGES

Unit: mm (ft in)

Arm length	ZAXIS75US-A		
	1.62 m (5'4")	2.12 m (6'11")	
A Max. digging reach	6 430 (21'1")	6 920 (22'8")	
A' Max. digging reach (on ground)	6 260 (20'6")	6 760 (22'2")	
B Max. digging depth	4 110 (13'6")	4 610 (15'1")	
B' Max. digging depth (8' level)	3 760 (12'4")	4 330 (14'0")	
C Max. cutting height	7 210 (23'8")	7 610 (25'0")	
D Max. dumping height	5 120 (16'10")	5 510 (18'1")	
E Min. swing radius	1 810 (5'11")	2 170 (7'1")	
F Max. vertical wall	3 670 (12'0")	4 210 (13'10")	
G Min. swing radius height	5 590 (18'4")	5 610 (18'5")	
Bucket digging force	ISO	55 kN (5 600 kgf, 12 400 lbf)	
	SAE : PCSA	47 kN (4 800 kgf, 10 600 lbf)	
Arm crowding force	ISO	38 kN (3 900 kgf, 8 600 lbf)	32 kN (3 300 kgf, 7 280 lbf)
	SAE : PCSA	36 kN (3 700 kgf, 8 200 lbf)	31 kN (3 200 kgf, 7 100 lbf)

Excluding track shoe lug

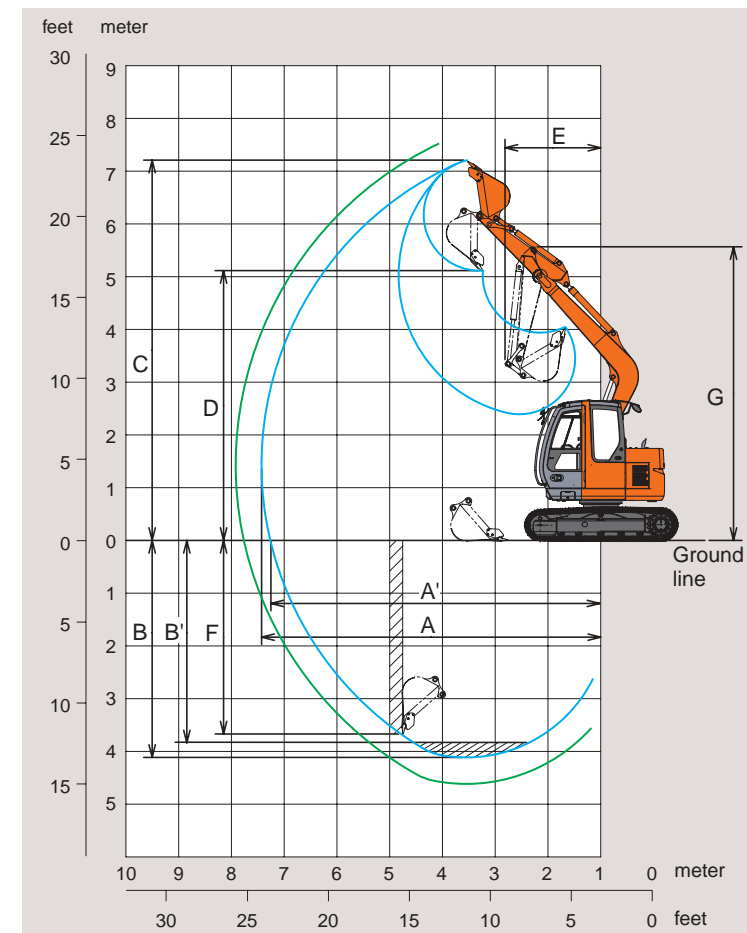

## METRIC MEASURE

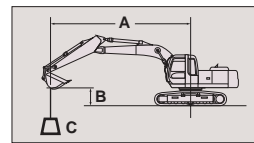

A: Load radius  
B: Load point height  
C: Lifting capacity

### ZAXIS75US

Rating over-side or 360 degrees Rating over-front Unit: 1 000 kg

Conditions	Load point height	Load radius										At max. reach				
		2 m		3 m		4 m		5 m		6 m				meter		
Boom 3.72 m	6 m															
	5 m					*1.35	*1.35					*0.90	*0.90	5.00		
	4 m					*1.33	*1.33					*0.87	*0.87	5.62		
Arm 1.62 m	3 m			*1.79	*1.79	*1.55	*1.55	1.09	1.40			0.79	*0.87	5.97		
	2 m			2.41	*2.66	1.53	*1.92	1.06	1.36			0.74	*0.90	6.11		
Bucket SAE,PCSA:0.28 m <sup>3</sup> CECE:0.25 m <sup>3</sup>	1 m					1.45	1.88	1.02	1.32			0.74	0.96	6.05		
	0 (Ground)			2.19	2.91	1.40	1.82	0.99	1.29			0.78	1.02	5.79		
Shoe 450 mm	-1 m	*3.02	*3.02	2.18	2.90	1.38	1.80	0.98	1.27			0.90	1.17	5.30		
	-2 m	*3.31	*3.31	2.20	2.92	1.38	1.81					1.20	1.55	4.47		
	-3 m	*3.30	*3.30	2.26	*2.47											

Conditions	Load point height	Load radius										At max. reach				
		2 m		3 m		4 m		5 m		6 m				meter		
Boom 3.72 m	6 m															
	5 m					*1.04	*1.04					*0.80	*0.80	6.61		
	4 m					*1.06	*1.06	1.13	*1.18			0.77	*0.77	6.15		
Arm 2.12 m	3 m			*1.34	*1.34	*1.29	*1.29	1.11	*1.27			0.68	*0.77	6.47		
	2 m			*2.17	*2.17	1.56	*1.67	1.07	1.37	0.76	0.99	0.64	*0.79	6.60		
Bucket SAE,PCSA:0.28 m <sup>3</sup> CECE:0.25 m <sup>3</sup>	1 m			2.30	3.00	1.47	1.90	1.02	1.32	0.74	0.97	0.63	0.84	6.55		
	0 (Ground)			2.19	2.92	1.40	1.82	0.98	1.28	0.72	0.95	0.66	0.88	6.31		
Shoe 450 mm	-1 m	*2.73	*2.73	2.16	2.88	1.36	1.79	0.96	1.26			0.75	0.98	6.87		
	-2 m	*4.10	*4.10	2.16	2.88	1.35	1.78	0.96	1.25			0.93	1.22	6.15		
	-3 m	*4.04	*4.04	2.20	*2.89	1.38	1.81					1.45	*1.56	3.97		

Notes: 1. Ratings are based on SAE J1097.  
2. Lifting capacity of the ZAXIS Series does not exceed 75% of tipping load with hte machine on firm, level ground or 87% full hydraulic capacity.  
3. The load point is a hook (not standard equipment) located on the back of the bucket.  
4. \*Indicates load limited by hydraulic capacity.

## STANDARD EQUIPMENT

Standard equipment may vary by country, so please consult your Hitachi dealer for details.

### ENGINE

- P mode control
- E mode control
- 30 A alternator
- Dry-type air filter with evacuator valve (with safety element)
- Cartridge-type engine oil filter
- Cartridge-type fuel filter
- Radiator and oil cooler with dust protective net
- Radiator reserve tank
- Fan guard
- Isolation-mounted engine
- Auto-idle system

### HYDRAULIC SYSTEM

- E-P control system
- Quick warm-up system for pilot circuit
- Shockless valve in pilot circuit
- Boom-anti-drift valve
- Control valve with main relief valve
- Extra port for control valve
- Suction filter
- Full-flow filter
- Pilot filter
- Swing drain filter

### CAB

#### CRES (Corner pillar Reinforced Structure) cab

- OPG top guard fitted level I (ISO) compliant cab.
- All-weather sound-suppressed steel cab
- Tinted (bronze color) glass windows
- 4 fluid-filled elastic mounts openable front windows-upper, and lower and left side windows

- Intermittent windshield wipers
- Front window washer
- Adjustable reclining seat
- Footrest
- Electric double horn
- AM - FM radio with digital clock
- Auto-idle acceleration selector
- Seat belt
- Drink holder
- Cigar lighter
- Ashtray
- Storage box
- Glove compartment
- Floor mat
- Heater
- Pilot control shut-off lever
- Engine stop knob.

### MONITOR SYSTEM

- Meters:
  - Hourmeter and trip-meter, engine coolant temperature gauge and fuel gauge.
- Warning lamps:
  - Alternator charge, engine oil pressure, engine overheat, air filter restriction and minimum fuel level.
- Pilot lamps:
  - Engine preheat, work light, auto-idle
- Alarm buzzers:
  - Engine oil pressure and engine overheat

### LIGHTS

- 2 working lights (under of cab & boom)

### UPPERSTRUCTURE

- Undercover
- 1 380 kg (3 040 lb) counterweight
- Fuel level float
- Hydraulic oil level gauge
- Tool box
- Rearview mirror (right, rear & left side)
- Swing parking brake

### UNDERCARRIAGE

- Travel parking brake
- Travel motor covers
- Hydraulic track adjuster
- Bolt-on sprocket
- Upper rollers and lower rollers
- Reinforced track links with pin seals
- 450 mm (18") triple grouser shoes

### FRONT ATTACHMENTS

- WC thermal spraying
- Bucket clearance adjust mechanism
- Monolithically cast bucket link A
- Dirt seal on all bucket pins
- 1.62 m (5'4") arm
- 3.72 m (12'3") boom

### MISCELLANEOUS

- Standard tool kit
- Lockable machine covers
- Lockable fuel filling cap
- Skid-resistant handrails.
- Travel direction mark on track frame
- Onboard ICX

## OPTIONAL EQUIPMENT

Optional equipment may vary by country, so please consult your Hitachi dealer for details.

### CAB

- All-weather sound-suppressed steel cab with skylight
- Front glass lower guard
- Front glass upper guard
- Cab head guard
- Auto control air conditioner
- Armrests
- Hot & cool box
- Cloth covered adjustable reclining seat
- Cloth covered suspension seat
- Vinyl covered suspension seat
- Power sauce (12 V)
- Sun-shade
- Transparent skylight

### LIGHTS

- Additional light (on the top for cab) : 2 units
- Additional light (on the boom)
- Rear light

### FRONT ATTACHMENT

- 2.12 m (7'0") long arm
- 1.62 m (5'4") reinforced arm
- 2.12 m (7'0") reinforced long arm

### UNDERCARRIAGE

- 600 mm (24") grouser shoe
- 450 mm (18") flat shoe
- 500 mm (20") triangle shoe
- 700 mm (26") triangle shoe
- Dozer blade
- Track under cover

### ATTACHMENT

- Attachment basic piping
- Accessories for 2 speed selector
- Accessories for breaker
- Accessories for breaker & crusher

### OTHERS

- Swing motion alarm device with lamps
- Travel motion alarm
- Hose rupture valve
- Electric fuel refilling pump
- Fuel double filter
- Fuel auto air bleeding system
- High-quality full flow element
- Air cleaner double filters



---

*Comparative information based on current Japan domestic model.  
These specifications are subject to change without notice.  
Illustrations and photos show the standard models, and may or may not include optional  
equipment, accessories, and all standard equipment with some differences in color and features.  
Before use, go through Operator's Manual for proper operation.*

**Hitachi Construction Machinery Co., Ltd.**

**Head Office:** 5-1 Koraku 2-chome, Bunkyo-ku,  
Tokyo 112-8563, Japan

**Telephone:** 81-3-3830-8050

**Facsimile:** 81-3-3830-8202

**KS-E419P**

04.03 (HP/HP,GT<sub>3</sub>)

Printed in Japan