

# EX12

- Rated engine HP: 11.0 kW (15.0 PS)
- Operating weight: Canopy: 1 280 kg (2 820 lb)  
Cabin: 1 380 kg (3 040 lb)
- Backhoe bucket: PCSA heaped: 0.024 — 0.044 m<sup>3</sup>  
(0.03 — 0.06 cu yd)  
CECE heaped: 0.02 — 0.04 m<sup>3</sup>



## ATTRACTIVE LIGHTNESS OF CONTROLLABILITY

- OHS for smooth combined operations.
- Light and easily controllable hydraulic pilot-type control lever.
- Low noise design best-suited for work in urban areas.
- Small turning radius suited for narrow space.
- Bucket clearance adjustment device.
- Gate lock lever to be never left unlocked.

## ENGINE

Model	Isuzu 3KC1		
Type	Water-cooled, 4 cycle, 3 cylinder swirl combustion chamber type diesel engine		
Rated flywheel horsepower (DIN 6271, net)	11.0 kW (15.0 PS)	at 2 300 rpm	
Rated flywheel horsepower (SAE J1349, net)	11.0 kW (14.8 HP)	at 2 300 rpm	
Maximum torque	52 N·m (5.3 kgf·m, 38.3 lbf·ft)	at 2 000 rpm	
Piston displacement	0.98 l (59.8 cu in)		
Bore and stroke	74 mm x 76 mm (2.9" x 3.0")		
Batteries	1 x 12 V, 36 AH		

## HYDRAULIC SYSTEM

### OHS (Optimum Hydraulic System)

This system with two main pumps gives high independence to each actuator for easy and smooth combined operation. Such as travel/blade, travel/swing and travel/arm.

Main pumps	2-Gear pumps		
Maximum oil flow	2 x 15.0 l/min (2 x 4.0 US gpm, 2 x 3.3 Imp gpm)		
Pilot pump	1-Gear pump		
Maximum oil flow	9.2 l/min (2.4 US gpm, 2.0 Imp gpm)		

### Relief Valve Settings

Implement circuit	17.2 MPa (175 kgf/cm <sup>2</sup> , 2 489 psi)
Swing circuit	8.8 MPa (90 kgf/cm <sup>2</sup> , 1 280 psi)
Travel circuit	17.2 MPa (175 kgf/cm <sup>2</sup> , 2 489 psi)
Pilot circuit	3.9 MPa (40 kgf/cm <sup>2</sup> , 569 psi)

### Hydraulic Cylinders

High-strength piston rods and tubes. Cylinder cushion mechanisms provided in boom and boom swing cylinders to absorb shocks at stroke ends.

### Dimensions

	Quan.	Bore	Stroke
Boom	1	55 mm (2.2")	455 mm (1'6")
Arm	1	55 mm (2.2")	395 mm (1'4")
Bucket	1	55 mm (2.2")	315 mm (1'0")
Boom swing	1	60 mm (2.4")	380 mm (1'3")
Blade	1	65 mm (2.6")	100 mm (3.9")

## CONTROLS

Pilot controls (for front and swing operations), light touch and excellent controllability

## SUPERSTRUCTURE

### Swing Mechanism

High-torque, axial piston motor with planetary reduction gear is bathed in oil. Swing circle is single-row, shear-type ball bearing with induction-hardened internal gear. Internal gear and pinion gear are immersed in lubricant. Swing shockless valve built in swing motor absorbs shocks when stopping swing, ensuring smooth stops. Also counter balanceless system is employed for smooth operation when starting and stopping swing. Swing lock (pin lock type) is provided for transporting.

Swing speed	10.0 min <sup>-1</sup> (10.0 rpm)
Boom swing angle	Canopy Left: 90°, Right: 50° Cabin Left: 70°, Right: 50°

### Operator's Cab (Factory Option)

Independent roomy cab, conforming to ISO\* Standards. Reinforced glass windows on all 4 sides for all-round visibility. Front window (upper side), fully openable, are spring-assisted for easy storing in the cab and for absorbing shocks during lowering.

\*International Standard Organization

## UNDERCARRIAGE

### Tracks

Tractor-type undercarriage. Heavy-duty track frame of all welded structure. Top-grade materials employed for heavy-duty operation. Side frames are rigidly welded to the track frame. Rugged track frame and sloped side frames for easy mud removal.

### Numbers of Rollers and Shoes on Each Side

Upper rollers	1
Lower rollers	3
Track shoes	32

### Traction Device

Each track driven by a high-torque, axial piston travel motor through planetary reduction gear, allowing counterrotation of the tracks.

Travel speeds	0 to 2.2 km/h (1.37 mph)
Maximum traction force	8.8 kN (900 kgf, 1 980 lbf)
Gradeability	30° (58%) continuous

## WEIGHTS AND GROUND PRESSURE

Equipped with 1.64 m (5'5") boom, 0.82 m (2'5") arm and 0.041 m<sup>3</sup> (0.05 cu yd; PCSA heaped) bucket.

Shoe type	Shoe width	Standard undercarriage	
		Operating weight	Ground pressure
Rubber (canopy) (cabin)	230 mm (9")	1 220 kg (2 684 lb)	23.5 kPa (0.24 kgf/cm <sup>2</sup> , 3.4 psi)
	230 mm (9")	1 320 kg (2 904 lb)	25.5 kPa (0.26 kgf/cm <sup>2</sup> , 3.7 psi)
*Double grouser (canopy) (cabin)	230 mm (9")	1 260 kg (2 816 lb)	24.5 kPa (0.25 kgf/cm <sup>2</sup> , 3.6 psi)
	230 mm (9")	1 360 kg (3 036 lb)	26.5 kPa (0.27 kgf/cm <sup>2</sup> , 3.8 psi)

\*Mark is standard specification.

## SERVICE REFILL CAPACITIES

	liters	US gal	Imp gal
Fuel tank	20	5.3	4.4
Engine coolant	3.5	0.9	0.8
Engine oil	4.5	1.2	1.0
Travel final device (each side)	0.33	0.09	0.07
Hydraulic tank	29	7.7	6.4

### Buckets

Capacity m <sup>3</sup> (cu yd)	CECE heaped	Width mm (ft in)		No. of teeth	Weight kg (lb)	Recommendation	
		Without side cutters	With side cutters			1.64 m (5'5") boom (2'5") arm (3'4") arm	1.02 m (3'4") arm
0.024(0.03)	0.02	225(8.9")	250(9.8")	2	25(55)	○	○
0.035(0.05)	0.03	325(12.8")	350(13.8")	3	29(63.8)	○	○
*0.041(0.05)	0.035	385(15.2")	410(16.1")	3	31(68.2)	○	□
0.046(0.06)	0.04	425(16.7")	450(17.7")	3	32(70.4)	○	△
	A: Arm crowd force		kN (kgf, lbf)		7.6 (800, 1 760)	7.1 (730, 1 600)	
	B: Bucket digging force		kN (kgf, lbf)		7.34(1 160, 2 552)		

\*Marks are standard specifications

- Suitable for materials with density of 2 000 kg/m<sup>3</sup> (3 370 lb/cu yd) or less
- Suitable for materials with density of 1 600 kg/m<sup>3</sup> (2 750 lb/cu yd) or less
- △ Suitable for materials with density of 1 100 kg/m<sup>3</sup> (1 850 lb/cu yd) or less

## CANOPY TYPE

### LIFTING CAPACITIES

Side: Rating over-side or 360 degrees

Front: Rating over-front

With dozer blade above ground

Unit: ton (lb)

Condition	Load point height (m/ft)	Load radius				At max. reach		
		2 m (6'7")		3 m (9'10")		Side	Front	@max. lift
		Side	Front	Side	Front			
Boom: 1.64 m (5'5") Arm: 0.62 m (2'1") Bucket	2 (6'7") 1 (3'3")	*0.25 (550) 0.25 (550)	*0.25 (550) 0.30 (660)	0.13 (286) 0.16 (352)	0.16 (352) 0.11 (242)	0.14 (308) 0.14 (308)	2.96 (660) 3.23 (717)	
PCSA: 0.041 m <sup>3</sup> (0.05 cu yd) CECE: 0.035 m <sup>3</sup> Grouser shoe 230 mm (9.1")	0 (Ground) -1 (-3'3")	0.23 (506) 0.23 (506)	0.28 (616) 0.28 (616)	0.12 (264) 0.15 (330)	0.15 (330) 0.12 (264)	0.12 (264) 0.15 (330)	3.05 (672) 3.05 (672)	

With dozer blade on ground

Unit: ton (lb)

Condition	Load point height (m/ft)	Load radius				At max. reach		
		2 m (6'7")		3 m (9'10")		Side	Front	@max. lift
		Side	Front	Side	Front			
Boom: 1.64 m (5'5") Arm: 0.62 m (2'1") Bucket	2 (6'7") 1 (3'3")	*0.25 (550) 0.25 (550)	*0.25 (550) *0.42 (926)	0.13 (286) 0.16 (352)	*0.25 (550) 0.11 (242)	*0.25 (550) 0.14 (308)	2.96 (660) 3.23 (717)	
PCSA: 0.041 m <sup>3</sup> (0.05 cu yd) CECE: 0.035 m <sup>3</sup> Grouser shoe 230 mm (9.1")	0 (Ground) -1 (-3'3")	0.23 (506) 0.23 (506)	*0.53 (1166) 0.39 (866)	0.12 (264) 0.15 (330)	*0.29 (638) 0.24 (528)	*0.27 (594) 0.24 (528)	3.05 (672) 3.05 (672)	

- Notes:
1. Rating are based on SAE J1097.
  2. Lifting capacity does not exceed 75% of tipping load with the machine on firm, level ground or 87% of full hydraulic capacity.
  3. The load point is a hook (not standard equipment) located on the back of the bucket.
  4. \*Indicates load limited by hydraulic capacity.

### DIMENSIONS

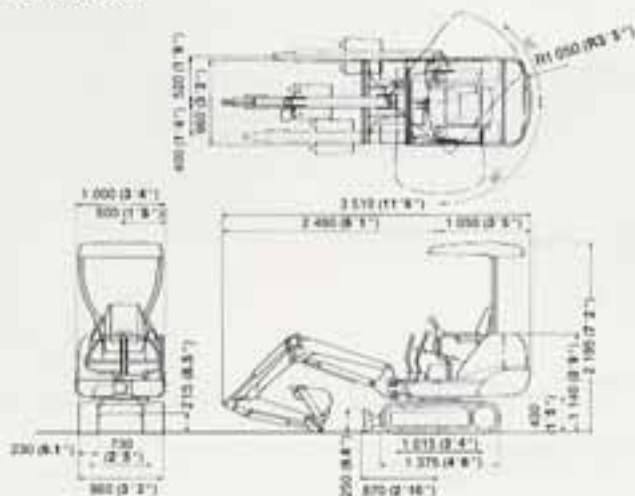

### WORKING RANGES

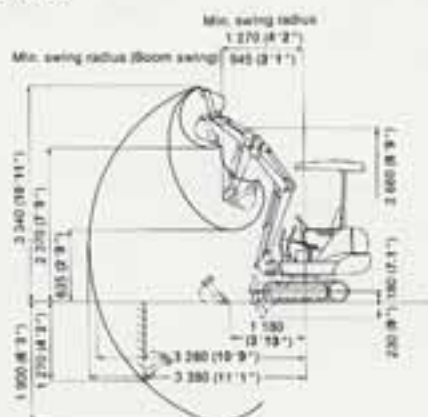

## CABIN TYPE

### LIFTING CAPACITIES

Side: Rating over-side or 360 degrees

Front: Rating over-front

With dozer blade above ground

Unit: ton (lb)

Condition	Load point height (m/ft)	Load radius				At max. reach		
		2 m (6'7")		3 m (9'10")		Side	Front	@max. lift
		Side	Front	Side	Front			
Boom: 1.64 m (5'5") Arm: 0.62 m (2'1") Bucket	2 (6'7") 1 (3'3")			0.13 (286) 0.16 (352)	0.16 (352) 0.11 (242)	0.14 (308) 0.14 (308)	2.96 (660) 3.23 (717)	
PCSA: 0.041 m <sup>3</sup> (0.05 cu yd) CECE: 0.035 m <sup>3</sup> Grouser shoe 230 mm (9.1")	0 (Ground) -1 (-3'3")	0.23 (506) 0.23 (506)	0.34 (746) 0.30 (660)	0.15 (330) 0.15 (330)	0.15 (330) 0.12 (264)	0.14 (308) 0.15 (330)	3.05 (672) 3.05 (672)	

With dozer blade on ground

Unit: ton (lb)

Condition	Load point height (m/ft)	Load radius				At max. reach		
		2 m (6'7")		3 m (9'10")		Side	Front	@max. lift
		Side	Front	Side	Front			
Boom: 1.64 m (5'5") Arm: 0.62 m (2'1") Bucket	2 (6'7") 1 (3'3")			0.13 (286) 0.16 (352)	*0.42 (926) 0.16 (352)	0.14 (308) 0.14 (308)	2.96 (660) 3.23 (717)	
PCSA: 0.041 m <sup>3</sup> (0.05 cu yd) CECE: 0.035 m <sup>3</sup> Grouser shoe 230 mm (9.1")	0 (Ground) -1 (-3'3")	0.23 (506) 0.23 (506)	*0.53 (1166) 0.40 (880)	0.15 (330) 0.15 (330)	*0.29 (638) 0.24 (528)	0.14 (308) 0.15 (330)	3.05 (672) 3.05 (672)	

- Notes:
1. Rating are based on SAE J1097.
  2. Lifting capacity does not exceed 75% of tipping load with the machine on firm, level ground or 87% of full hydraulic capacity.
  3. The load point is a hook (not standard equipment) located on the back of the bucket.
  4. \*Indicates load limited by hydraulic capacity.

### DIMENSIONS

Unit: mm (in)

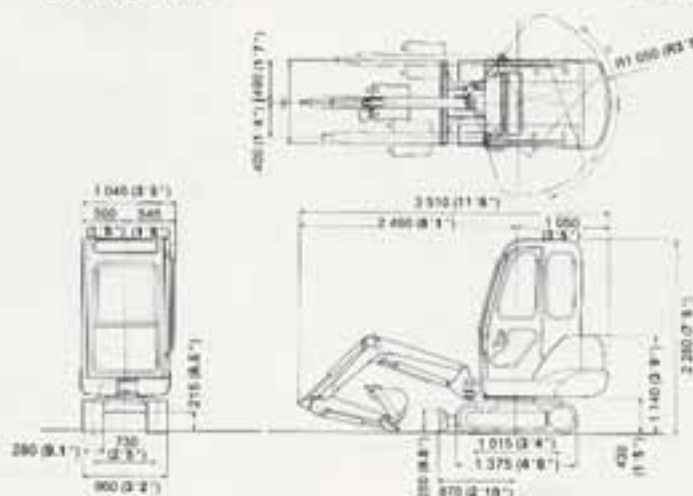

### WORKING RANGES

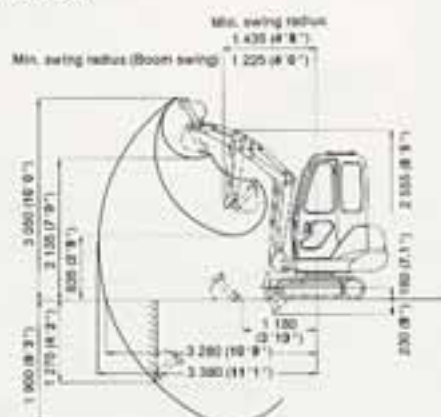



- 1 Fail-safe gate lock lever**  
With the fail-safe gate lock levers, the control levers (wing type) can be locked without fail, allowing access to the operator's seat.
- 2 Hydraulic pilot control levers**  
Front and swing control levers are hydraulically pilot-controlled for light and comfortable operation. What more, ergonomically designed lever grip enhances operating ease and comfort.
- 3 Body cover protection weight**  
A body may be protected from damage by any external shock during operation.
- 4 Engine key stop of car feeling**  
With the adoption of stop motor, an engine may be stopped only by turning the key off. Moreover the engine hood or fuel cap can be locked and unlocked with the engine key.
- 5 Easy-to-read monitor panel**  
With the monitor panel, the operator can check machine conditions of a glance from his seat.



- 6 Easy engine access**  
The engine cover opens completely to allow easy access during engine maintenance.
- 7 Compact traction mechanism**  
Compact yet sturdy travel mechanism, with travel piping provided within track frame.
- 8 Bucket clearance adjust mechanism**  
It can easily eliminate loose movement of the bucket by merely replacing the shim. O-ring seal is provided at the pin, located at the arm top, to seal out dirt, extending lubricating intervals.

These specifications are subject to change without notice.

### Hitachi Construction Machinery Co., Ltd.

Head Office: Nippon Bldg., 6-2, 2-chome, Ohtemachi,  
Chiyoda-ku, Tokyo 100, Japan

Telephone: Tokyo (03) 3245-6361

Facsimile: Tokyo (03) 3246-2606

Telex: J32539 HITACONJ

Cable Address: "TOKHITACHIKENKI"